



Thank you for selecting JELD-WEN products. Attached are JELD-WEN's recommended installation instructions for Custom Wood and Fiberglass doors. Read these instructions thoroughly before beginning. They are designed to work in most existing applications, however; existing conditions may require changes to these instructions. If changes are needed, they are made at the installer's risk. For installations other than indicated in these instructions, contact a building professional.

To adequately protect your door, please refer to "Appropriate Protection for Exterior Doors" for information on protection requirements at [www.jeld-wen.com/resources](http://www.jeld-wen.com/resources).

Not all door types may be installed into every wall condition in all areas. Consult your local building code official for applicable building codes and regulations. Local building code requirements supersede recommended installation instructions.

**Please Note!** Doors must be installed square, level and plumb and on a flat surface (without twist or warp). We also recommend that all components be finished prior to installation. See our recommended finish maintenance instructions at [www.jeld-wen.com/resources](http://www.jeld-wen.com/resources). Poor installation or finish may result in denial of warranty claims for operational or performance problems.

**Note to Installer:** Provide a copy of these instructions to the building owner. By installing this product, you acknowledge the terms and conditions of the limited warranty as part of the terms of the sale.

## SAFETY & HANDLING

### SAFETY

- Read and fully understand ALL manufacturers' instructions before beginning.
- Do not work alone. Two or more people are required. Use safe lifting techniques.
- Use caution when handling glass. Broken or cracked glass can cause serious injury.
- Wear protective gear (e.g. safety glasses, gloves, ear protection, etc.).
- Operate hand/power tools safely and follow manufacturer's operating instructions.
- Use caution when working at elevated heights.

### MATERIALS & PATIO DOOR HANDLING

- Heed material manufacturers' handling and application instructions.
- Protect adhesive surfaces from dirt, moisture, direct sunlight and folding over onto themselves.
- Handle in vertical position; do not drag on floor.
- Do not put stress on joints, corners or frames.
- Store door in dry, well-ventilated area to allow air circulation.
- Protect from exposure to direct sunlight during storage.
- Install only into vertical walls and when conditions and sheathing are dry.

**IF INJURY OCCURS , IMMEDIATELY SEEK MEDICAL ATTENTION!**

## NEEDED MATERIALS & TOOLS

### Installation Materials Required:

- Shims
- 1-1/2" 6d finish nails
- 3" 12d finish nails
- 3" corrosion resistant screws
- Exterior silicone sealant
- Exterior waterproof construction adhesive
- Low pressure foam
- Wood matched putty stick
- Sill pan made from plastic sheeting
- Set of flashings
- 6" self-adhesive flashing
- Spray adhesive
- Backer Rod

### Tools Required:

- 3-foot level
- 6-foot level
- Tape measure
- Hammer
- Finish nail gun
- Nail set
- Duckbill pliers
- 1/8" drill bit
- Caulking gun
- Safety glasses
- Miter saw
- 1" chisel or router
- Bar clamp
- Screw gun
- Utility knife



# Custom Door System Overview

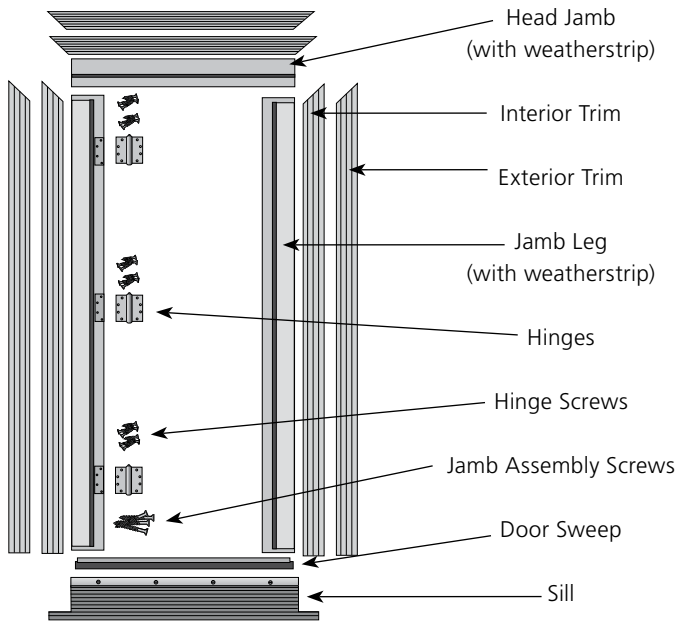

**System 1**

Check to ensure that all parts listed on the jamb boxes are present and in good condition *before* removing existing entry or beginning to install the new unit.

**Please Note:**

*Check for hinges, door sweep, trim, jambs, sill and screws.*

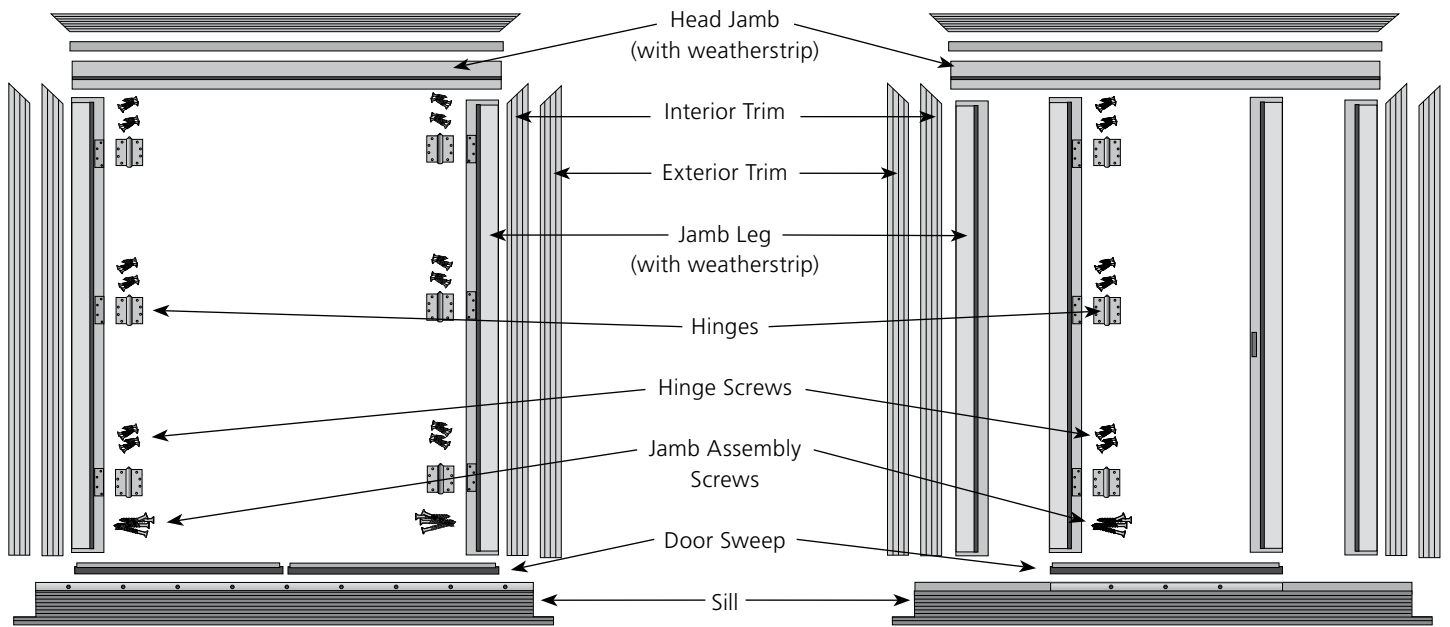

**System 2**

**Systems 3, 4, 5**

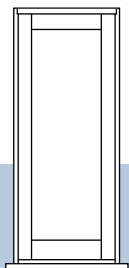

**System 1**  
Single Door

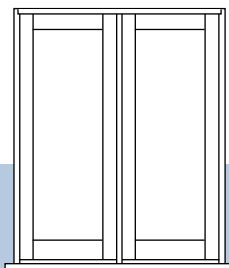

**System 2**  
Pair of Doors



**System 3**  
Door & Sidelight

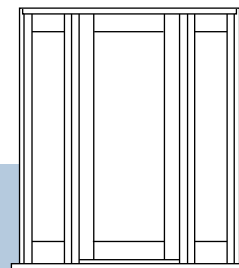

**System 4**  
Door & Pair of Sidelights

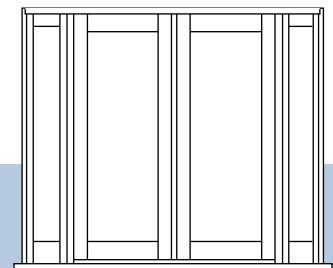

**System 5**  
Pair of Doors & Pair of Sidelights

# Prepare the Rough Opening

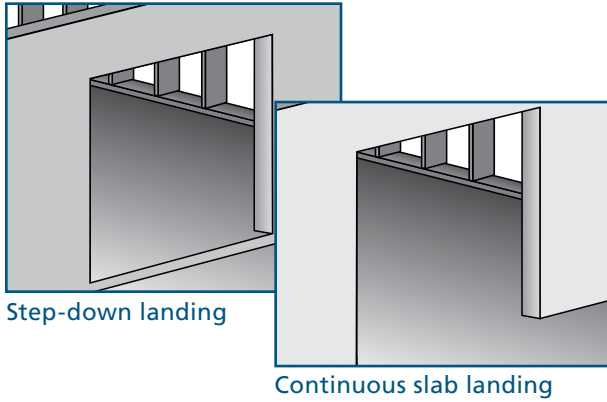

These instructions cover two door sill conditions: the **step-down landing** and the **continuous slab landing**. The installation methods vary slightly between the two landing types.

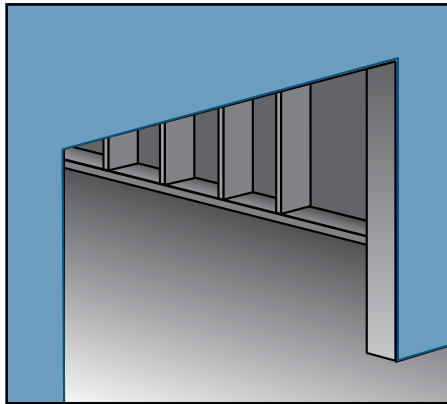

Fig. 1 Cut building wrap

Prepare the rough opening. The rough opening is to be 3/4" wider and 3/4" taller than the net outside jamb dimension of the unit. Check floor for level (measurements must be within 1/8"). Check walls or studs for straightness (measurements must be within 1/4") and plumb (measurements must be within 1/8"). Correct before installing.

For doors with a curved transom top, see **diagram 1 "Door with Curved Transom Top"**. Rough opening must be level (measurements must be within 1/8") before starting; adjust as needed.

1. Clean rough opening and surrounding sheathing with a clean, dry cloth, beginning at the top.
2. Trim building wrap flush with rough opening on header and sides; and sill edge if door has a rise.

Apply five 3/8" beads of sealant across the sill as follows (**Fig. 2**):

- One 1/2" from the interior edge.
- One 1/2" from the exterior edge.
- One across the center of the sill.
- One on each side where the jambs meet the floor.

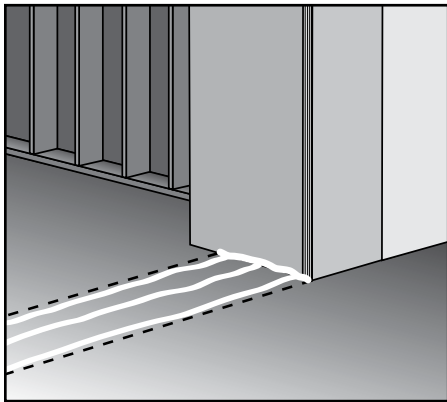

Fig. 2 Apply sealant across sill

## Diagram 1. Door with Curved Transom Top

- Ensure framing is sufficient around transom perimeter to allow exterior trim to be nailed every **8"** to the structure.
- Prepare rough opening in same manner as for standard door (**Fig. A**).
- Install transom top in same manner as for regular door except for the following:
  - Apply flashing support in short **6"-12"** sections around the curved perimeter.
  - Apply conformable self-adhesive flashing to backside of flashing support and frame.
  - Apply **6"** wide conformable self-adhesive flashing onto flashing support, sheathing, and building wrap around curved edge (**Fig. B**).

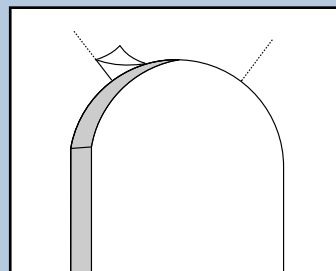

Fig. A Cut back building wrap

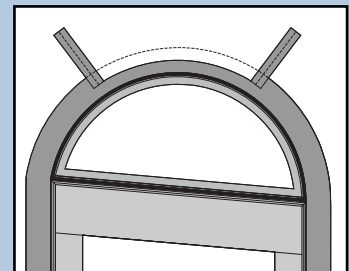

Fig. B Conformable flashing

# Prepare the Rough Opening - Continued

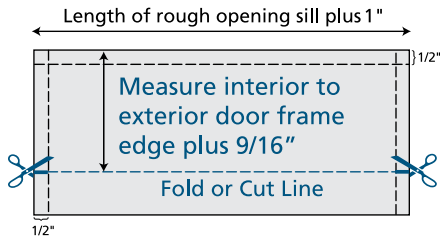

Fig. 3 Sill pan template

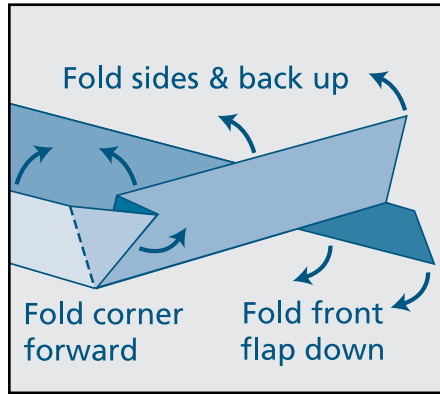
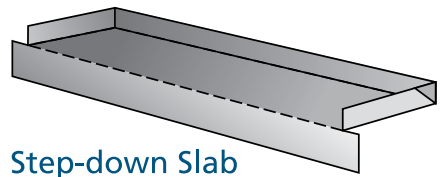

Fig. 4 Fold sill pan



## Step-down Slab

Fig. 5 Finished sill pan for step down landing

**Prepare Sill Pan** - The sill pan is a three-sided box made of plastic sheet material that sits in on the rough opening. It is designed to catch water that infiltrates the rough opening and divert it to the outside. This prevents damage from water collecting on the rough opening sill. Door installations that have a step-down landing (as opposed to a door that sits directly on a continuous slab) have slightly different sill pans.

1. Prepare the sill pan as follows (**Fig. 3**):
  - For a 2" x 4" wall, the width of the plastic sheeting should be at least 6".
  - For a 2" x 6" wall, the width of the plastic sheeting should be at least 9".
  - The length should be determined by measuring the length of the rough opening plus 1".
2. Crease lines in sill pan using a straight edge as follows (**Fig. 3**):
  - Lightly crease a line inset 1/2" along both ends and one side of the plastic sheeting.
  - Measure the width of the door frame (not including the brickmold), and add 9/16".
  - Take this distance and measure out from the back side; crease a line the length of the plastic sheeting.
3. Cut 1/2" in on both ends of this line (**Fig. 3**).
4. Fold the sill pan as follows:
  - Fold the three 1/2" sides up; use duckbill pliers to fold corners to outside of pan on short sides (**Fig. 4**).
  - For door with step-down landing: fold down at remaining crease line (**Fig. 5**).
  - Trim height of fold-down to rise of step if necessary.
  - For door on continuous slab, cut along the remaining crease line.
5. Place sill pan in rough opening so the open side faces the exterior.

**NOTE:** *Door sits inside sill pan; back dam of the sill pan should just clear the back edge of door sill when it is placed in the rough opening.*

# Prepare the Rough Opening - Continued

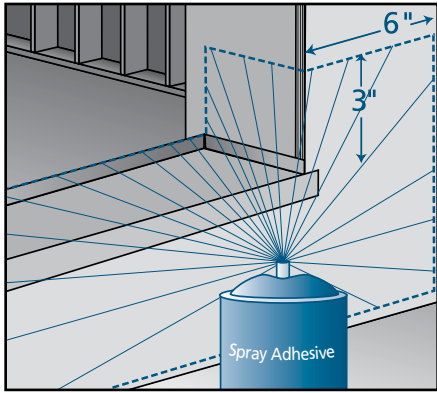

Fig. 6. Apply adhesive spray

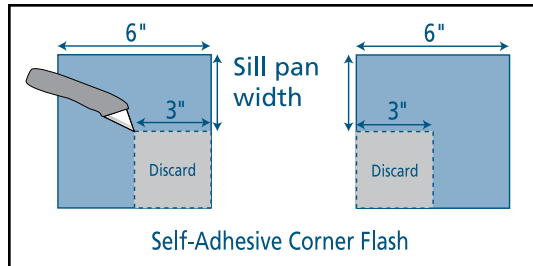

Fig. 7 Cut self-adhesive flashing

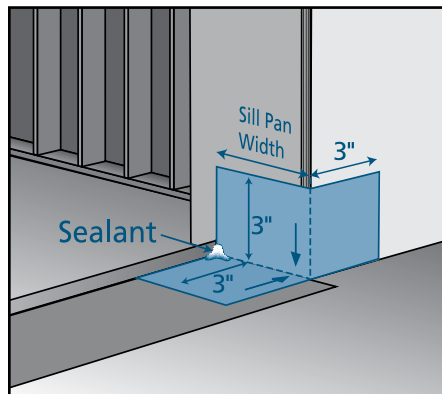

Fig. 8 Apply self-adhesive tape (continuous slab)

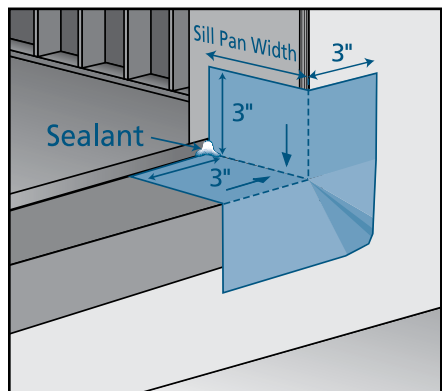

Fig. 9 Apply self-adhesive flashing (step-down landing)

1. Coat the sill pan with spray adhesive extending 3" up both side jambs; spray the vertical face of the rise, if applicable, as shown in **Fig. 6**. (Follow manufacturer's instructions for tack time.)
2. Apply self-adhesive flashing to the sill pan floor as follows:
  - Cut adhesive flashing to sill length; for continuous slab, cut to width of sill pan.
  - Remove backing paper.
  - Carefully apply to rough opening sill, flush with back dam of sill pan and fully covering the bottom of the sill pan.
    - Fold flat onto rise (if applicable) or cut to sill pan width if on continuous slab.
  - Smooth out any bubbles or creases with a j-roller.
3. Apply self-adhesive flashing to lower corners as follows:
  - Cut two pieces (one for each corner of the rough opening sill) 6" x distance between the exterior and the interior edge of the door frame + 3".
  - For doors on continuous slab, cut out the inside corner as shown in **Fig. 7**:
    - Remove paper backing from one piece.
    - Adhere to one bottom corner tightly at 90° with 3" up the side and wrap flashing onto wall sheathing (**Fig. 8**); do not stretch or tear flashing; eliminate as many wrinkles as possible.
  - For step-down landings:
    - Remove paper backing from one piece.
    - Adhere to one bottom corner tightly at 90° with 3" up the side and overlap onto the vertical face of the rise (**Fig. 9**); do not stretch or tear flashing; eliminate as many wrinkles as possible.
    - Press self-adhesive flashing tight into corners with j-roller.
    - Repeat in opposite bottom corner.
4. Seal back corners of sill pan with sealant (**Fig. 9**).

# Assemble Door Jamb Components

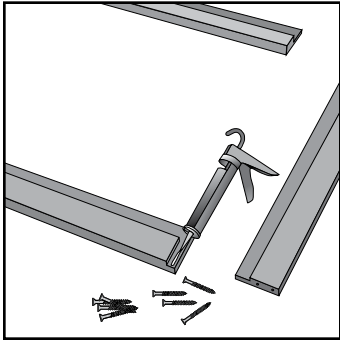

Fig. 10

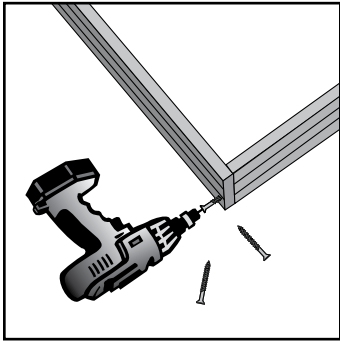

Fig. 11

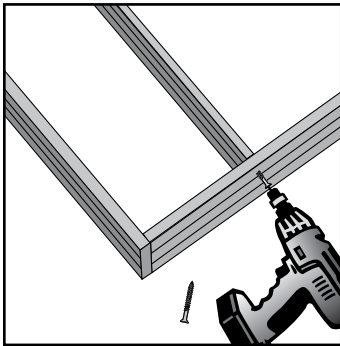

Fig. 12

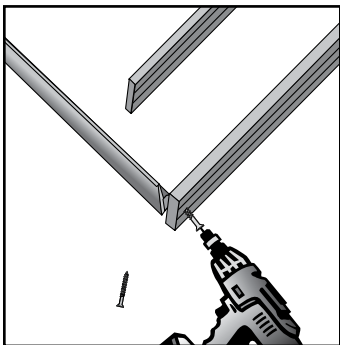

Fig. 13

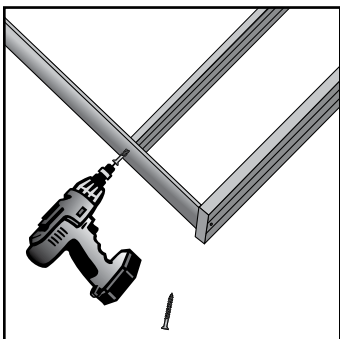

Fig. 14

1. Lay jamb components out on a flat protective surface prior to assembly (refer to photos on page 1):
  - A. SYSTEMS 1 & 2 – Two jamb legs, one header, one sill.
  - B. SYSTEM 3 – Two jamb legs, one mull post, one header, one sill
  - C. SYSTEMS 4 & 5 – Two jamb legs, two mull posts, one header, one sill.
2. Prior to assembly, apply a light bead of caulk along all connecting surfaces of jamb components for sealing and adhesion (**Fig. 10**).
3. Attach and fasten jamb legs to the head jamb, using 1-1/2" screws into the pre-drilled holes on the jamb leg. Make sure the edges of the head and side jamb line up and are even with each other. Snug screws so corners are square and tight, with no gaps (**Fig. 11 & Fig. 12**).
4. Attach and fasten jamb legs to sill using 1-1/2" screws into pre-drilled holes on outside jamb (**Fig. 13**).  
  
SYSTEMS 3, 4 & 5 – Attach mull post into notch at sill. Fasten using 1-1/2" screws into pre-drilled holes from bottom of sill into mull post (**Fig. 14**).
5. Clean up any excess caulk.

# Install Jamb System

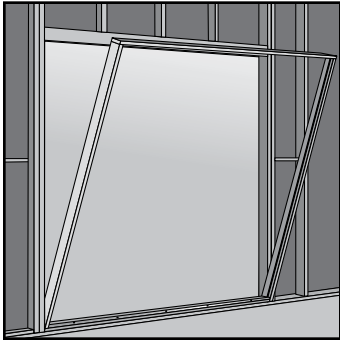

Fig. 15

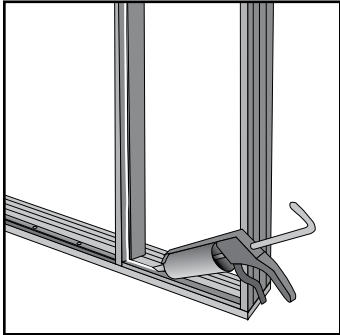

Fig. 16

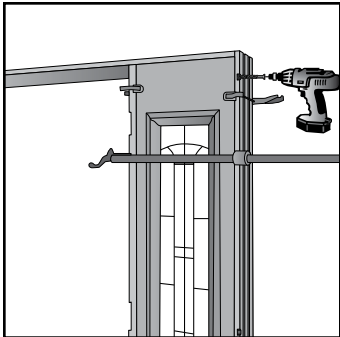

Fig. 17

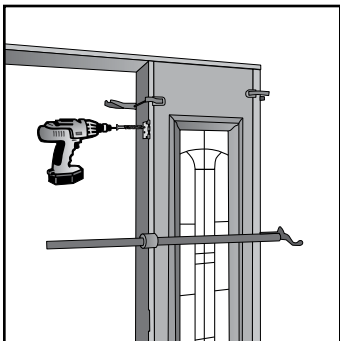

Fig. 18

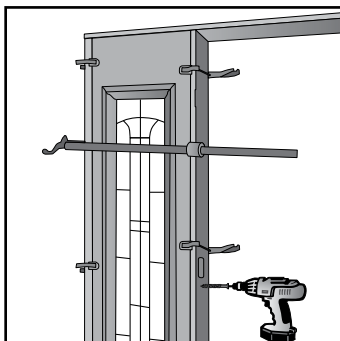

Fig. 19

1. With jamb system assembled, tip into rough opening, checking for good fit (**Fig. 15**). Mark exact location of sill on floor for construction adhesive and future fit, then remove unit.
2. Installation of sidelights (if not applicable, continue to Prepare Jamb System for Installation on page 11)
  - A. *Silight top, bottom and side edges must be sealed before installation into the jamb.*
  - B. Insert silight into the jamb in the direction as marked from the factory. Silight for hinge side has pre-drilled pilot holes for hinge screws. Check for fit, then remove.
- C1. For Custom Fiberglass Doors Only:** Insert weatherstrip in the kerfed area around the silight of the jamb. Once the door is completely installed, the finished trim strip may be applied with a 1-1/2" 6d finish nail. (See **Fig. 16.1** for details.)
- C2. For Custom Wood Doors:** To weatherproof sidelights, apply a bead of caulk along the inside rabbeted corner the entire length of the silight jamb leg, silight mull post, silight head jamb, and silight sill (**Fig. 16**).
- D. Insert sidelights back into jamb.
- E. Use bar clamps to tighten jambs to silight.
- F. Anchor jamb leg to silight through back of rabbeted portion of jamb with 1-1/2" screws at top, bottom and center. More anchor screws may be necessary on larger sidelights (**Fig. 17**).
- G. Anchor hinge side mull post to silight using two 2" brass screws through hinge (**Fig. 18**).
- H. Anchor strike side mull post to silight, using a 1-1/2" screw under lock strike location (**Fig. 19**). Anchor top of mull post to silight using two 1-1/2" finish nails approximately 2" down from head jamb through rabbeted face of jamb. Anchor bottom of mull post to silight using two 1-1/2" finish nails approximately 2" up from sill into rabbeted portion of mull post.

## NOTE:

*No screw holes or nail locations are marked on the strike side mull post.*

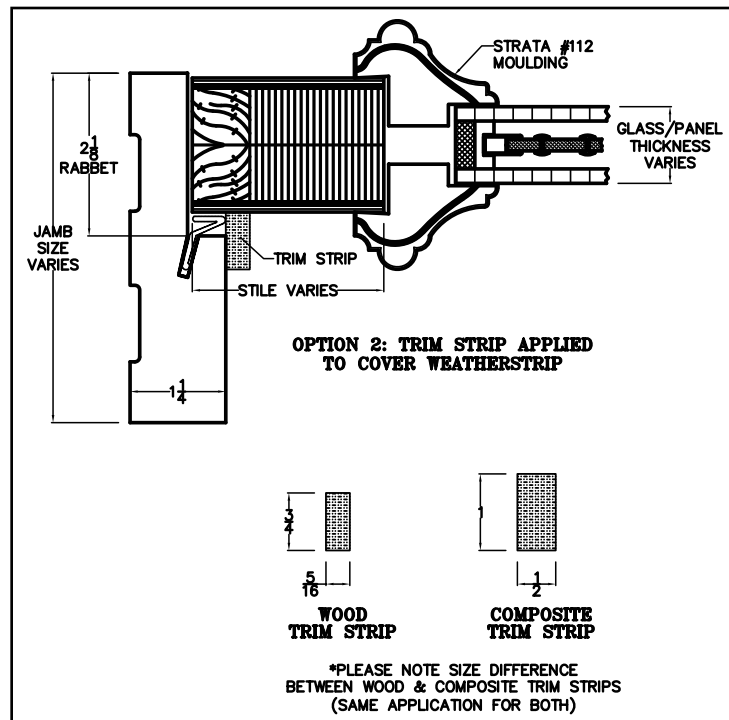

Fig. 16.1

# Prepare Jamb System for Installation

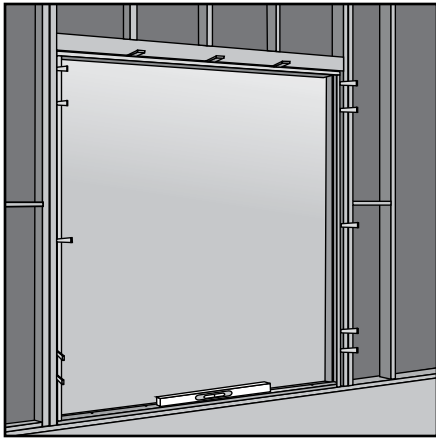

Fig. 20

## Jamb and Door Installation

1. Tip jamb unit into rough opening, paying close attention to prior marking for sill location.
2. CHECK SILL FOR LEVEL. Correct before installing (**Fig. 20**).
3. Checking jambs for straightness, level and plumb, apply shims from interior and exterior of house as follows: (These numbers and locations of shims are meant only to serve as a minimum requirement. Depending on the application and size of the unit, more shims may be required.)

### A. SYSTEMS 1 & 2 (**Fig. 21**); shim as follows:

- Shim the jambs as follows:
  - Behind each hinge.
  - At the top and bottom of each jamb (at the pre-drilled holes behind the weatherstrip).
  - Behind the strike plate.
  - Head jamb at center and 6" from each end.
  - For 8' doors, more shims are needed at the jambs.

### B. SYSTEMS 4 & 5 (**Fig. 22**); additional shimming as follows:

- On the sidelight jamb leg at approximately 2" and 30" from both the top and bottom of the frame.
- Above the head jamb at the center of the door(s) and directly above the mull.

### C. SYSTEM 3; additional shimming as follows:

- On the sidelight jamb leg and the strike or hinge jamb leg at approximately 2" and 30" from both the top and bottom of the frame.
- Above the head jamb 6" from each corner, at the center of the door and directly above the mull.

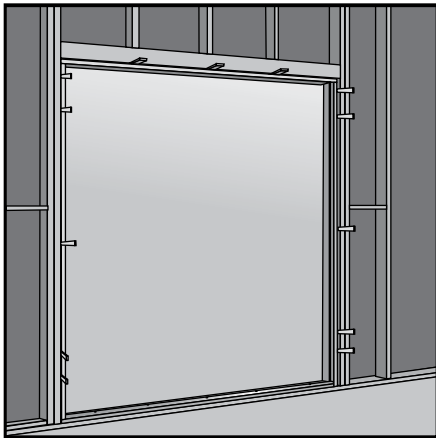

Fig. 21

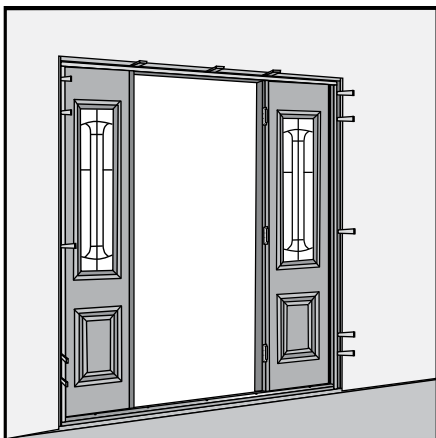

Fig. 22

## NOTE:

### COMPOSITE FRAME INSTALLATION

### RECOMMENDED PRACTICES FOR JAMB INSTALLATION

- A. Fastener and shim spacing should be set at 16" or less.
- B. Pre-drill and countersink for 2" fastening screws under the area covered by the weatherstrip.
- C. Index the shims to fasten through and make sure to locate one set of shims under each hinge.
- D. At least one screw per hinge should be long enough to run through shim into the supporting wall stud.

Fastening casing and brickmold should be the same as for any wood jamb. Any strike prep or other machining can be made with traditional tools, etc.

4. Cross side jambs with string, checking for square, and plumb to ensure no rack. Adjust shims as necessary (**Fig. 23**).

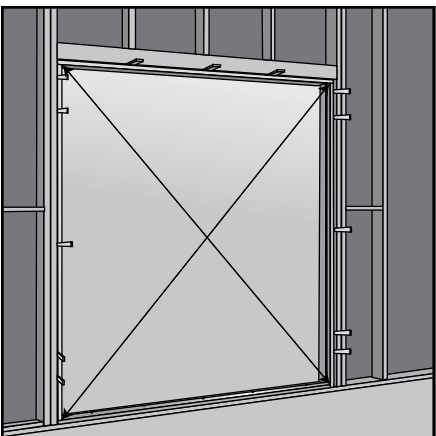

Fig. 23

# Attach Jamb to Studs



Fig. 24

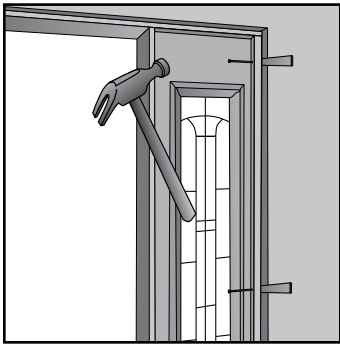

Fig. 25

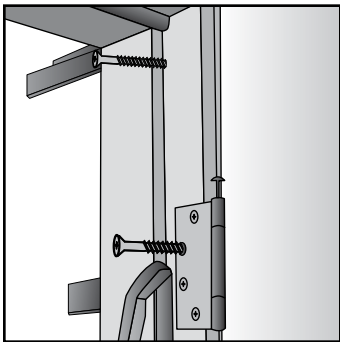

Fig. 26

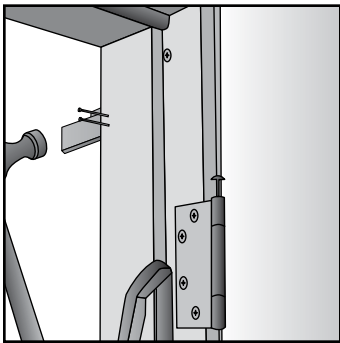

Fig. 27



Fig. 28

1. Temporarily fasten jamb to studs:
  - A. SYSTEMS 1, 2 & 3 - Fasten using 3" screw through top and bottom pre-drilled anchor holes behind weatherstrip (**Fig. 24**).
  - B. SYSTEM 4 - Tightly installed shims should be enough to hold unit.
  - C. SYSTEM 5 - Fasten by partially driving one 3" finish nail through both the top and bottom shim of the sidelight jamb legs (**Fig. 25**).

## 2. Attaching jamb to studs

### NOTE:

*Apply lubricant (wax or bar soap) to screw threads before driving screws.*

#### A. SYSTEMS 1 & 2:

- Fasten jamb leg to stud by using 3" corrosion resistant screws through both top and bottom pre-drilled anchor holes behind weatherstripping on hinge side jamb, drive two 2" brass finish screws into stud through hinge (**Fig. 26**). If applicable, drive 3" corrosion resistant screws through the jamb at strike plate location. Fasten head jamb by driving 3" screw through pre-drilled anchor holes behind weatherstrip.
- Check unit for square, plumb and even door reveal.
- If necessary, drill and countersink holes behind weatherstrip then fasten with 3" corrosion resistant screws at additional locations on jamb legs.
- At approximately the same level as the anchor screws and hinges, drive two 3" finish nails through face of jamb into stud to help secure jamb (**Fig. 27**).

### NOTE:

*Screws and nails must go through the shims.*

#### B. SYSTEMS 4 & 5:

- Anchor jamb legs by driving a minimum of two 3" finish nails through the exterior face of the jamb into the stud at both 2" and 30" from the top and bottom of the unit (**Fig. 28**). Refer to **Fig. 22** for nailing locations. Additional anchoring locations may be necessary depending on size of the unit.
- Anchor head jamb by driving two 3" finish nails through the face of the jamb into the stud at the center of each door and sidelight at the shim locations.

### IMPORTANT:

*Nails must go through the shims.*

#### C. SYSTEM 3:

- Attaching jamb to stud is combination of the two above procedures.

# Finishing Installation

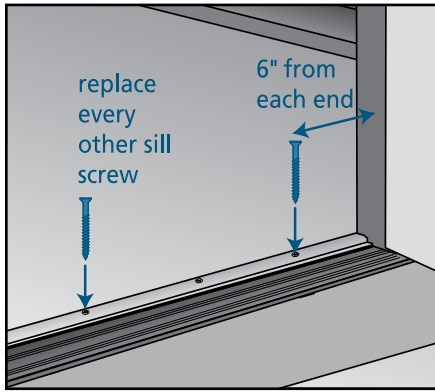

Fig. 29

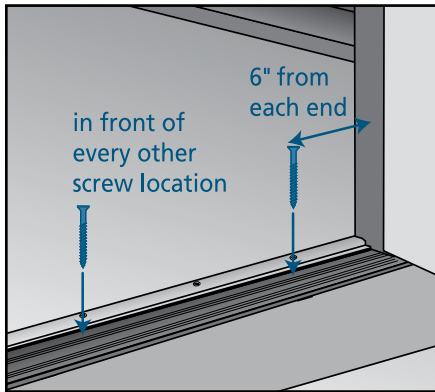

Fig. 30

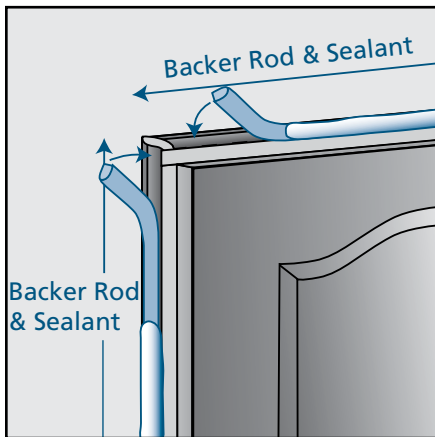

Fig. 31

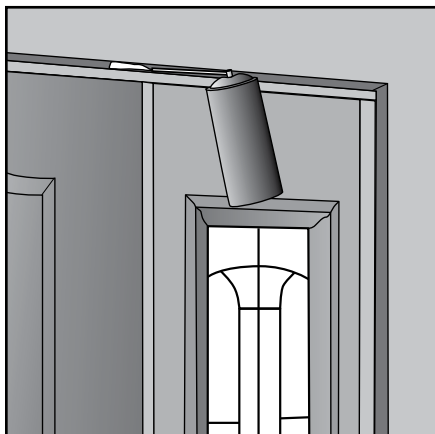

Fig. 32

1. Structurally secure sill as follows:

**NOTE:**

*For wood framing, use #8x3" corrosion resistant screws. For concrete, use 3/16" x 2-1/2" self-tapping concrete screws.*

- A. Coat threads of screws with sealant before insertion into hole.
- B. Drill appropriate pilot holes as necessary.
- C. Cover top of screws with sealant.

- Da. If door has a **traditional threshold**, secure as follows (**Fig. 29**):

- For single panel swing doors, place two structural screws 6" from each end.
- For multiple panel doors, replace the existing screws at each end of the threshold and every other existing screw in between with structural screws.

- Db. Some inswing doors require an adjustable threshold; **if adjustable threshold** (Fig. 30):

- For single panel swing doors, place two structural screws 6" from each end.
- For multiple panel doors, place a screw in front of every other screw location into the sill.

2. Hang the door slab in the frame by screwing the hinges in place on the frame. Assure proper fit.
3. On the exterior, apply a continuous sealant joint between the frame and the rough opening at the jambs and header using backer rod and sealant (**Fig. 31**).
4. On the interior apply low pressure foam between the outside of jamb and the stud to seal any gaps (**Fig. 32**).

**NOTE:**

*Follow manufacturer's instructions for proper low pressure foam usage.*

# Finishing Installation

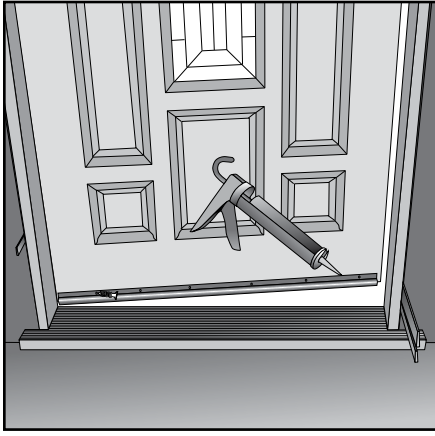

Fig. 33

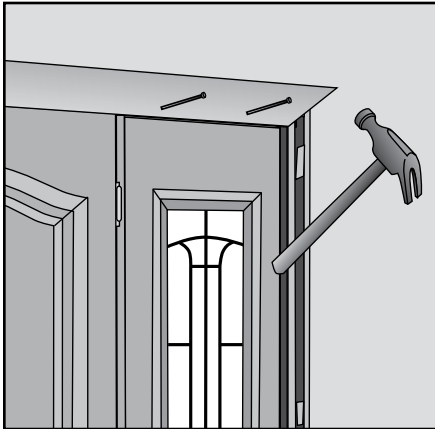

Fig. 34

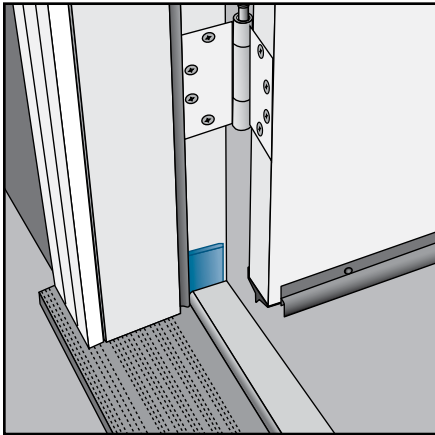

Fig. 35

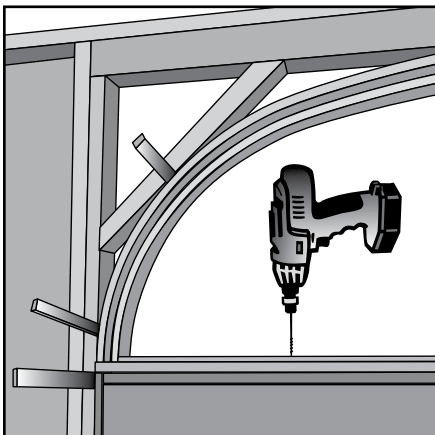

Fig. 36

5. Installing hardware:
  - A. Install the lock set, following manufacturer's instructions. Use chisel or router to mortise out for strike plate on jamb or astragal.
  - B. Install the door sweep onto the bottom of the door. Attach using 1/4" screws on face of door sweep. Run a bead of caulk on the top exterior outer edge to prevent water from entering the sweep (**Fig. 33**).
6. Installing exterior and interior trim

- A. Trim any sealant or shims protruding from the jamb.
- B. Measure, cut and set one trim leg. Reveal of the trim to be approximately 3/16" from inside edge of jamb. Measure both ends of head trim, cut, if necessary, then set (**Fig. 34**). Measure, cut and set other trim leg.

### IMPORTANT:

*Trim is intentionally left long for more flexibility in the field. It may be necessary to cut to length and miter depending on your application.*

- C. Anchor the casings to jamb with 1-1/2" or 3" finish nails every 12" to 18".
  - D. JELD-WEN recommends running a bead of caulk around the edge of the exterior trim where it meets the wall.
7. Fill all nail holes with a wood matched putty stick.
  8. JELD-WEN has included a set of 1-3/4" by 1-1/4" compression weatherstrip wedges. Install these at lower rabbeted corners of the jambs to help ensure a weathertight seal (**Fig. 35**).
  9. Optional Transom Installation

- A. Run a generous bead of caulk on the top of the door head jamb.
- B. Set the transom jamb on the door head jamb.
- C. Drill countersunk pilot holes 12" from both ends and in the center of the rabbeted portion of the bottom transom jamb into the door head jamb.

### IMPORTANT:

*Stop the drill at 1-1/4" depth.*

- D. Fasten transom jamb to head jamb with 1-1/4" screws into pilot holes (**Fig. 36**).

# Finishing Installation

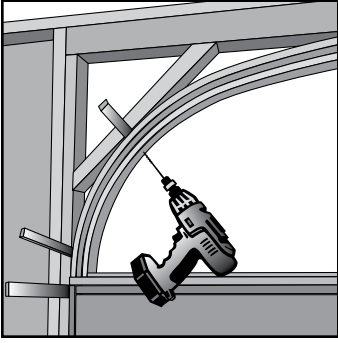

Fig. 37

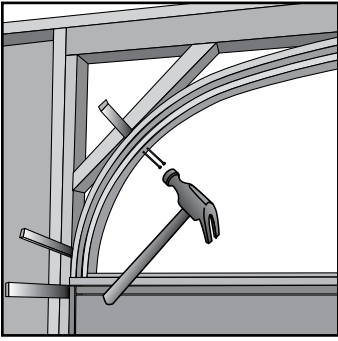

Fig. 38

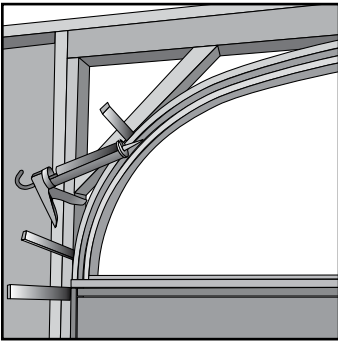

Fig. 39

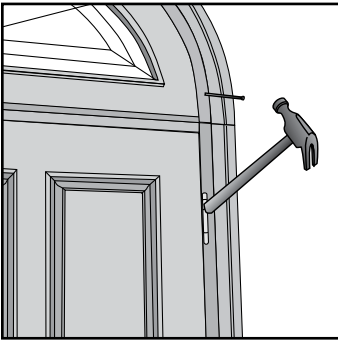

Fig. 40

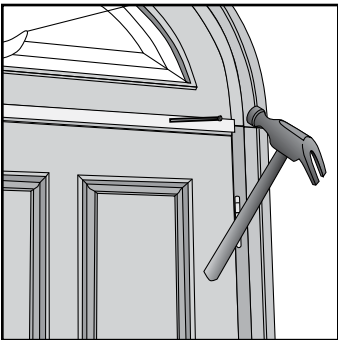

Fig. 41

- E. Shim transom jamb approximately every 16" to 24".
- F. Drill countersunk pilot holes on the rabbeted portion of the transom jamb through the location of every shim (**Fig. 37**). Fasten the transom jamb to the studs through these pilot holes with 3" corrosion resistant screws.
- G. To secure the jamb to the studs at every shim, drive two 3" finish nails through the face of the jamb into the stud (**Fig. 38**).

## NOTE:

*Steps 8-11 only apply if the transom sash was not factory installed.*

- H. Install transom sash to check for fit, then remove.
- I. Apply a bead of caulk along the inside corner of the rabbeted transom jamb (**Fig. 39**).
- J. Install transom sash.
- K. To secure transom sash to jamb, set quarter round stop and fasten with 1-1/2" finish nails (**Fig. 40**).
- L. Measure, trim and set interior and exterior trim to transom jamb. Fasten trim to frame with either 1-1/2" or 3" finish nails.

## NOTE:

*Trim is run long to allow more flexibility in the field.*

- M. Measure cut and set mullion covers. Caulk and fasten with 1-1/2" finish nails (**Fig. 41**).
- N. Fill all nail holes with wood matched putty stick.

# Trouble Shooting

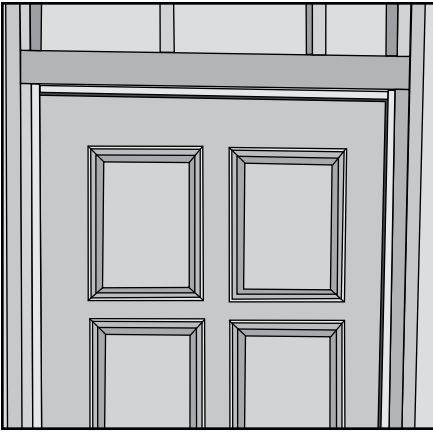

Fig. 42

## Problem #1

Reveal between door and lock side jamb is too tight (**Fig. 42**).

### Causes:

1. Hinge leafs not set flush into jamb and door.
2. Hinge leafs bent at knuckle, pushing door towards jamb.
3. Hinge side jamb over-shimmed at hinge locations, pushing door towards lock jamb.
4. Lock side jamb over-shimmed.
5. Door not anchored properly to stud at top hinge location.

## Problem #2

Reveal between door and jambs is too wide (**Fig. 43**).

### Causes:

1. Check reveal on hinges side to see if door is sagging in opening. Sagging may be due to the following:
  - A. Door not anchored properly to stud at top hinge location.
  - B. Top hinge leaf is bent at knuckle.
  - C. Top hinge not set flush into jamb or door.
2. Jamb not square. Check the following:
  - A. Sill for level.
  - B. Head jamb for level.
  - C. Jamb over-shimmed.

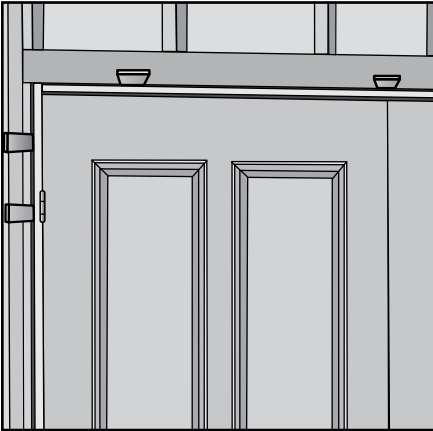

Fig. 43

## Problem #3

Top or bottom corner of door projects into house past jamb (**Fig. 44**).

### Causes:

1. Hinges not all set tight against back set of hinge prep on jamb or door.
2. Jamb is racked, one side of jamb kicks into the house while the other jamb kicks outside. This can be checked by using a 6-foot level on each jamb, or cross sighting the jambs with a string. The strings should just touch where they cross in the middle. If there is a gap between these two strings, this is the distance the frames are racked.

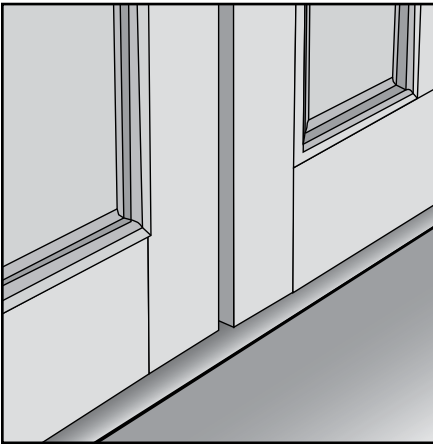

Fig. 44

# Weatherproofing the Door

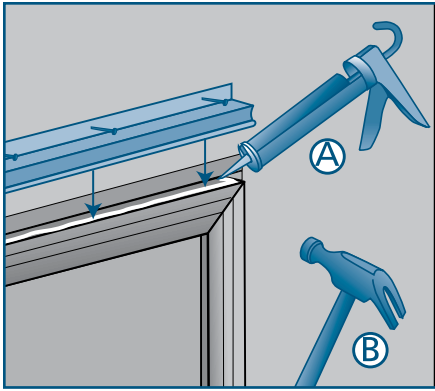

Fig. 45A & B

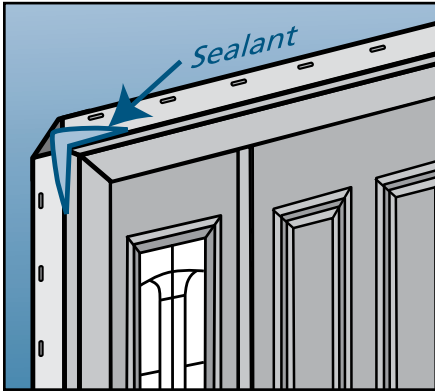

Fig. 46

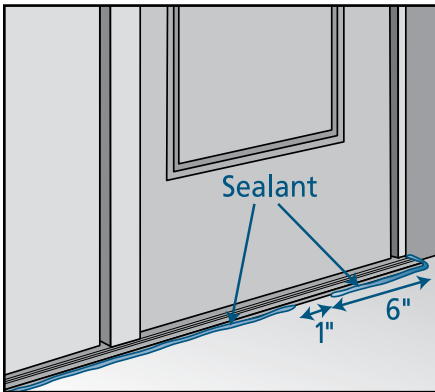

Fig. 47

## Drip Cap installation

1. Cut a piece of galvanized drip cap the length of the header brickmold plus **1/4"** to allow for **1/8"** overlap past the ends of the header brickmold.
  - Apply **1/4"** bead of sealant to top of the header brickmold along the front and side edges (**Fig. 45A**).
  - Nail drip cap in place; apply sealant to side edges (**Fig. 45B**).
2. Drive all nails into the brickmold completely but do not overdrive; do not dent brickmold; set the nail below the surface.
3. Apply sealant to the two upper corners as follows:
  - Follow sealant manufacturer's instructions for surface preparation and application.
  - Apply bead **1/4"** wide to corners extending 1" along both legs of the corner.
  - Use the back of a spoon (or similar shape) to form sealant into fillet shape (**Fig. 46**).
4. Apply additional sealant as follows:

For doors with step-down landing:

  - Apply a **1/4"** bead of sealant underneath the sill, leaving a **1"** gap **6"** from each end (**Fig. 47**).

For doors on continuous slab:

  - Apply a **1/4"** bead of sealant around the nose of the sill where it makes contact with the slab or step leaving a **1"** gap **6"** from each end of the sill nose.

Please visit [www.jeld-wen.com/resources](http://www.jeld-wen.com/resources) for warranty, finishing instructions and care and maintenance information.

Thank you for choosing

**JELD-WEN**  
WINDOWS & DOORS